



MODERN TERMINAL MARKET

FOR PERISHABLES AT RAI (HARYANA)



Terminal Markets are proposed to be set up at Nasik, Chandigarh, Rai, Bhopal, Nagpur, Patna, Mumbai and Kolkata in Public-Private Partnership. Detailed model Project Reports for the above markets have been prepared by National Institute of Agricultural Marketing (NIAM), Jaipur, NCDC (Kolkata) and Maharashtra State Agricultural Marketing Board (Mumbai) and are available at NIAM for further details. These markets would cover fruits, vegetables, flowers, aromatics, herbs, meat and poultry.

Arrival (MT) of some important Fruits & Vegetables at Rai (in M.T)

Fruits/Vegetables	Arrival
Banana	110335
Apple	19284
Citrus family	14693
Potato	159090
Onion	57722
Tomato	51792
Cauliflower	35729
Carrot	18959
Leafy vegetable	12785
Total	183392

Backward Linkage

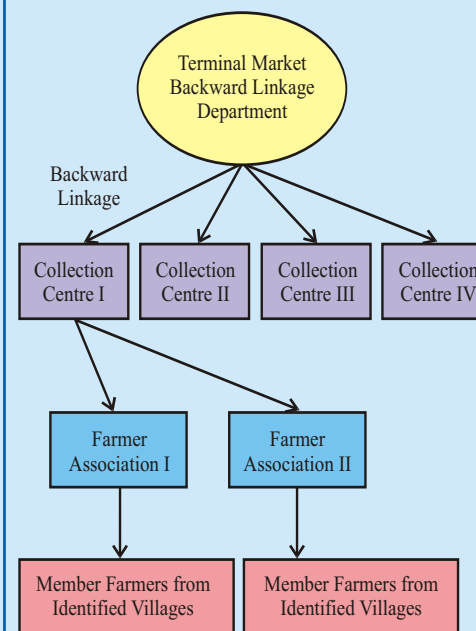

Public Private Partnership (PPP)

The Government of India has launched a scheme under which up to 25% subsidy is available for capital investment in Agricultural Marketing infrastructure with a Rs. 50 lacs subsidy ceiling for Private agencies, with no ceiling for State agencies. Alternative PPP models of equity structure for setting up and operation of Terminal Markets have been developed in association with YES Bank to take advantage of the scheme.

LAYOUT PLAN

FOOD PARK

FOOD PARK

EXISTING DEMARCATED ROAD

HARYANA TOURIST COMPLEX

LAND FOR FUTURE EXPANSION
AREA: 6845,42 SQ.M

LAND FOR FUTURE EXPANSION
AREA: 21910,025 SQ.M

GREEN BELT
TO CHANDIGARH

TO DELHI

LEGEND:

- AUCTION HALL
- AUCTION AREA COLD STORAGE
- GRADING/PACKING/WASHING
- TRANSITION / DISPLAY AREAS: PHASE I
- TRANSITION / DISPLAY AREAS: PHASE II
- LOADING/ UNLOADING PLATFORMS
- BIG WHOLESALE SHOPS
- COLD STORAGES
- RIPENING / PRECOOLING UNITS
- TRANSPORTERS SHOPS
- MAINTENANCE DEPTS
- ADMINISTRATION
- UTILITY /FOOD KIOSKS
- CONNECTING CORRIDORS/ PASSAGES
- TOILETS / WASH ROOM
- 12,00 M WIDE ROAD
- 24,00 M WIDE ROAD
- GREEN BELTS
- CIRCULATION & MOVEMENT PATTERN

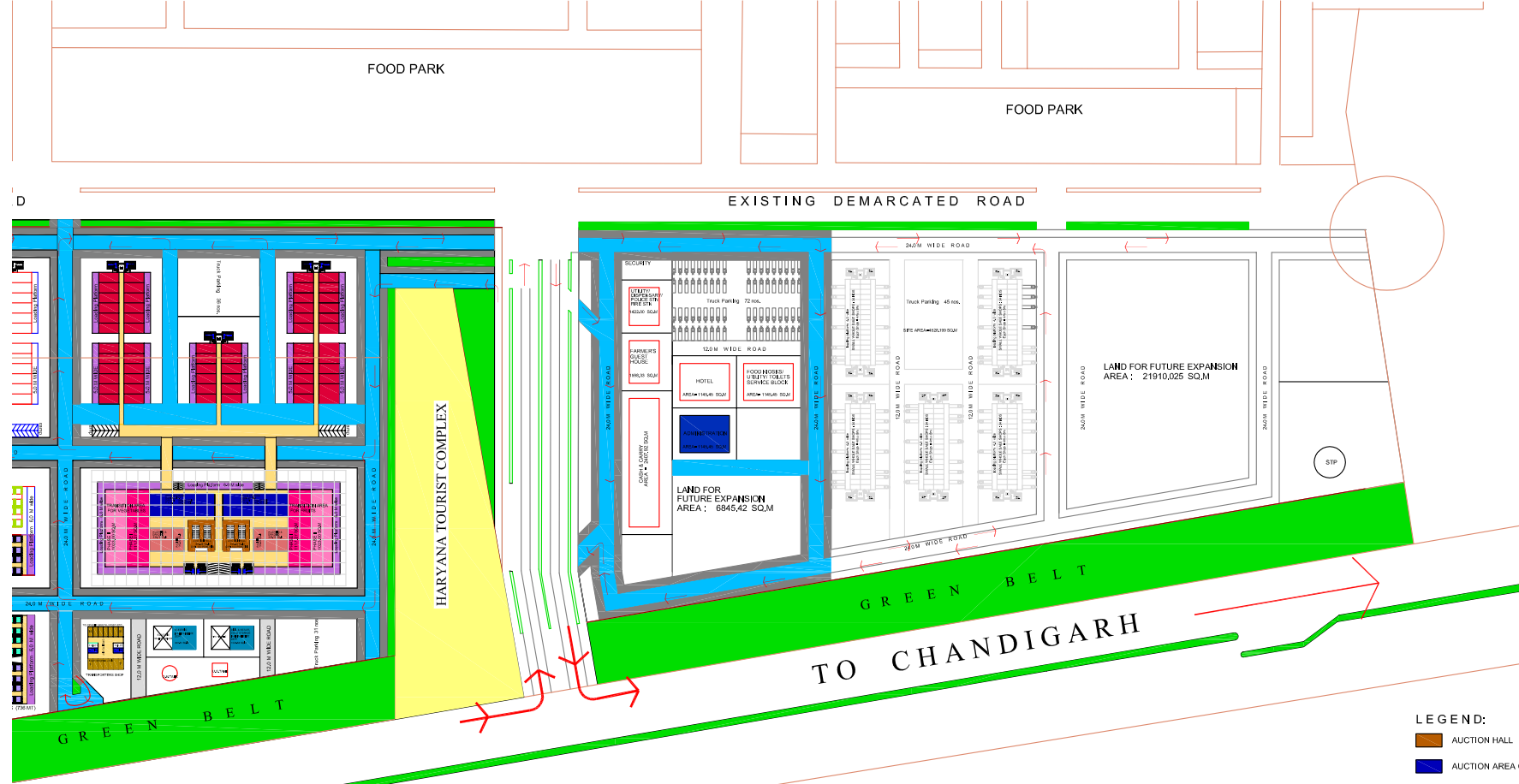

Route Map

of Roads Connecting the C.C. to Terminal Market

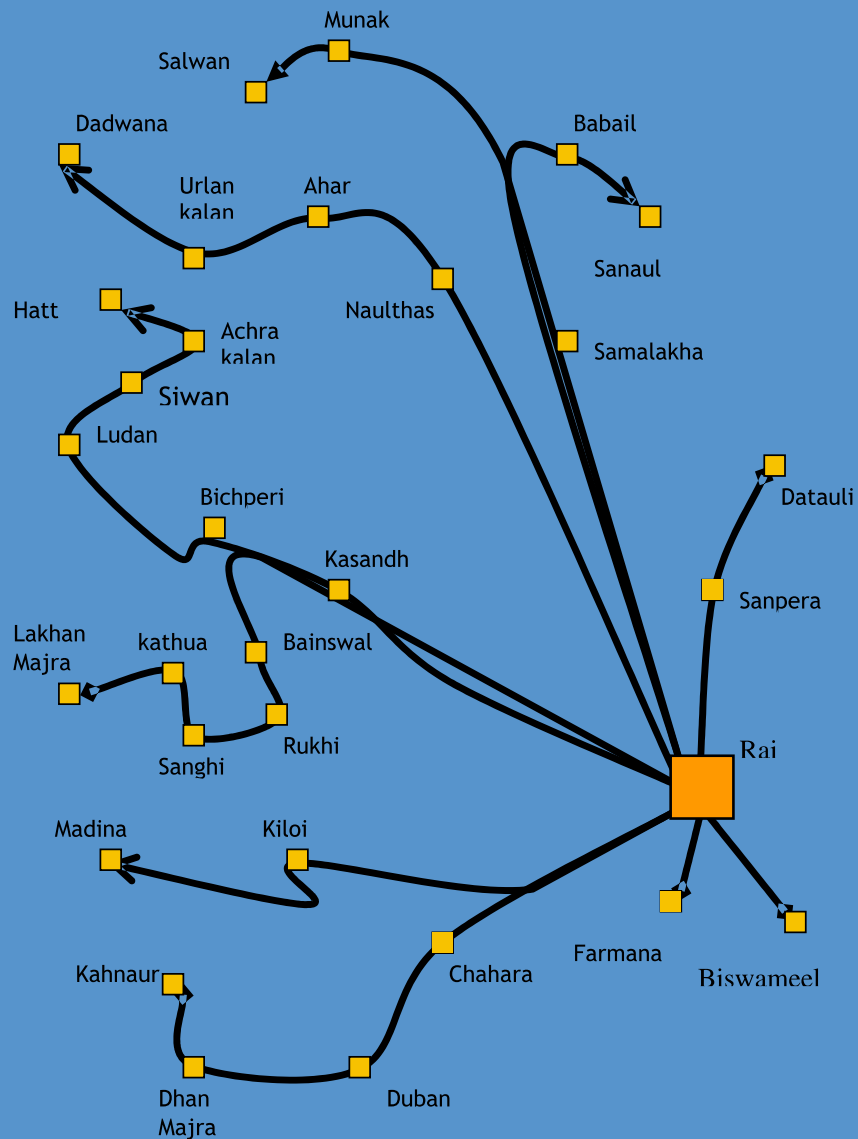

FINANCIAL & OPERATIONAL PROJECTIONS

Cost of Project including working capital approx. Rs.66 Crores

Financing

Share Capital	approx. 30%
Subsidy	approx. 25%
Term Loan	approx. 45%

Debt Equity Ratio	1.5
Debt Service Coverage	1.83
Breakeven (% of Capacity reached in 2nd year of Operation)	approx. 58%
I.R.R.	approx. 14%

ELECTRONIC AUCTION SYSTEM

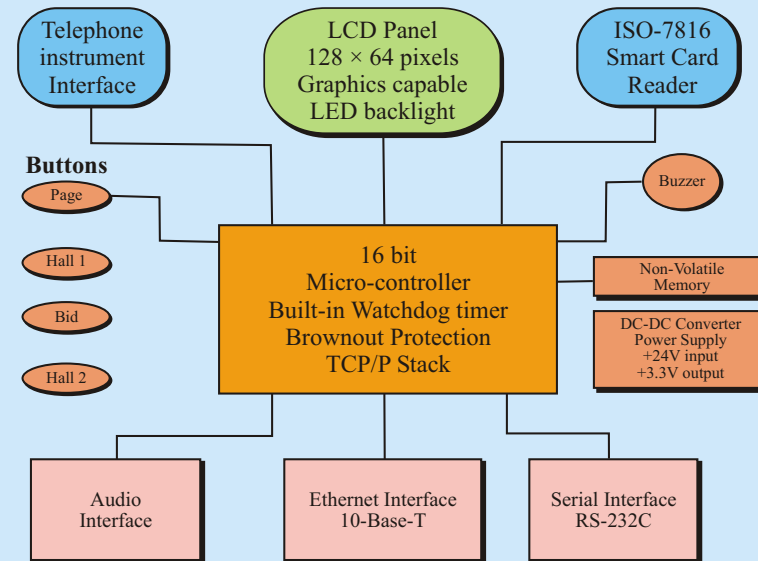

For Further information please contact:

THE DIRECTOR GENERAL

National Institute of Agricultural Marketing (NIAM)

Bambala, Kota Road, Jaipur- 303906. (Rajasthan)

Phone : 0141-2770027 • Fax : 0141-2771938, 2770027.

E-mail : www.niam.gov.in • dgniamjpr@gmail.com

